



شركة المصنع السعودي لأجهزة الإطفاء  
SAUDI FACTORY FOR FIRE EQUIPMENT Co.

Empowering  
a Safer Future for  
the Kingdom



## Foam/Water Cabinets SF9000 Series

- ❖ Recessed type cabinets
- ❖ Semi-Recessed type cabinets
- ❖ Surface type cabinets
- ❖ Self Stand type cabinets

Quality Approvals for Various Products and Services



# Foam / Water Cabinets

## Model: SF 9000 Series



- ❖ SFFECO Foam/Water Cabinet Model SF/9000 characterized for its high performance for attacking class A and B Fire within seconds.
- ❖ Designed for single man operation.
- ❖ Highly efficient in gas stations, petro-chemical plants, industrial premises, warehouses and in any area, requires protection from class A and B fires.
- ❖ Cabinet and door leaves are made of electro-galvanized steel sheet with a thickness of 1.2 mm. Optional Stainless Steel cabinets are available as per customer requirements.
- ❖ Cabinets are with all around folded edges without any sharp edges and burrs. The roof is sloped type.
- ❖ Cabinet painted with Powder Coated for elegant finish and protection from rust.
- ❖ Operating instructions are silk screen printed in English and Arabic inside the cabinet doors.
- ❖ We are fully capable to manufacture any type of foam cabinets as per customer designs or specifications.

## Cabinet Components

### Fire Hose Reel



Superior quality, 100% synthetic jacket hose, the outer fabric is made of circular woven synthetic fiber and root proof yarn, while inner layer is a substance of tropical rubber applied by means of a special vulcanizing technique ensures long life, elasticity and flexibility. Hose size 1.5 inch x 30 meter length, wrapped on swinging hose reel.

Hose reel is made of 1mm mild steel sheet and pressed out. The outer edge of the reel is rolled over to give a safe handling edge on the outer rims. The reel is mounted on swinging arm.

### Foam Proportioner



2" Foam proportioner or inductor. The design of the inductor enables an exact mixing rate of the passing water equipped with bypass system.

### Foam Can

Two canisters of 20 liter 3% foam concentrate. Different types of foam concentrates are available on request.



### Foam Branch Pipe



Foam branch pipe with shut off control valve, body made of aluminum and handle with hard rubber. It can throw foam between 15-20 meter depends on line pressure. Also it can be used as water jet pipe.

### Angle Valve



- ❖ Size 1.5": Brass body
- ❖ Hand wheel with steel epoxy coated
- ❖ UL/FM (Optional)

# Foam / Water Cabinets

## Model: SF 9000 Series

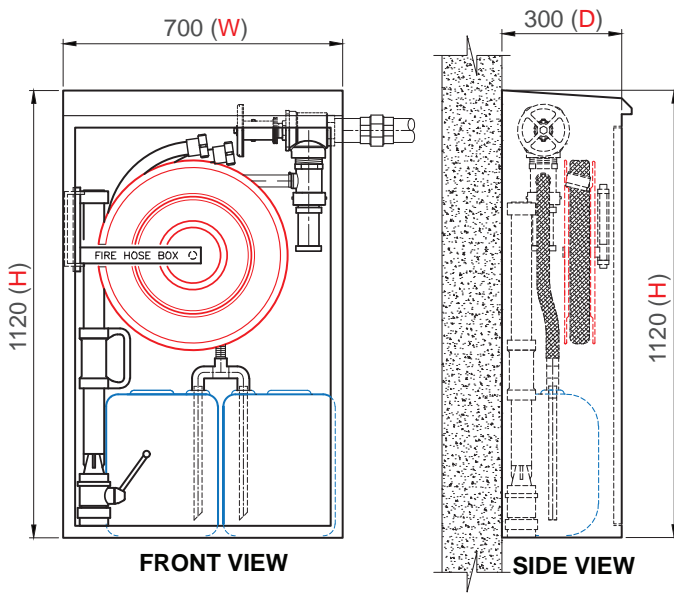

Suitable to use at Fire Class:



**A** Solid matters forming glowing residues. e.g. wood, rubber (car tires), paper, textiles.



**B** Liquid combustible matter e.g. petrol, oils, grease, ether, alcohol.

MODEL	WIDTH (W)	HEIGHT (H)	DEPTH (D)
SF9000	700	1120 (Sloped Roof)	300

All dimensions are in mm.

### Full Stainless Steel Construction (Door, Frame & Backbox)

- ❖ Finish : Hairline / Mirror finish
- ❖ Thickness : 0.9mm / 1mm / 1.2mm / 1.5mm / 2mm

### Full Electro Galvanized Steel Construction (Door, Frame & Backbox)

- ❖ Finish : Red / as per customer request
- ❖ Thickness : 0.9mm / 1mm / 1.2mm / 1.5mm / 2mm

### Backbox in Electro Galvanized Steel

- ❖ Finish : Red / as per customer request
- ❖ Thickness : 0.9mm / 1mm / 1.2mm / 1.5mm / 2mm

### Door and Frame in Stainless Steel

- ❖ Finish : Hairline / Mirror finish
- ❖ Thickness : 0.9mm / 1mm / 1.2mm / 1.5mm / 2mm

### Trim

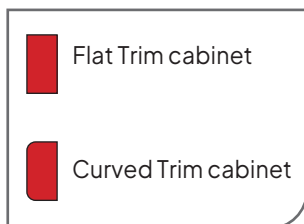

### Mounting Type

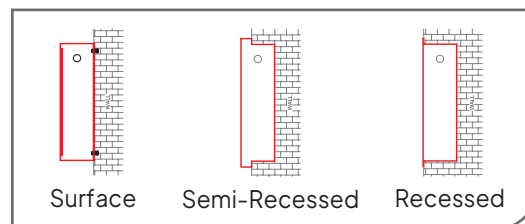

### Door Opening Type

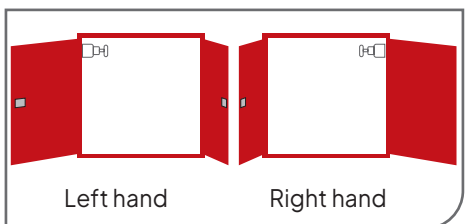

### Door Selection

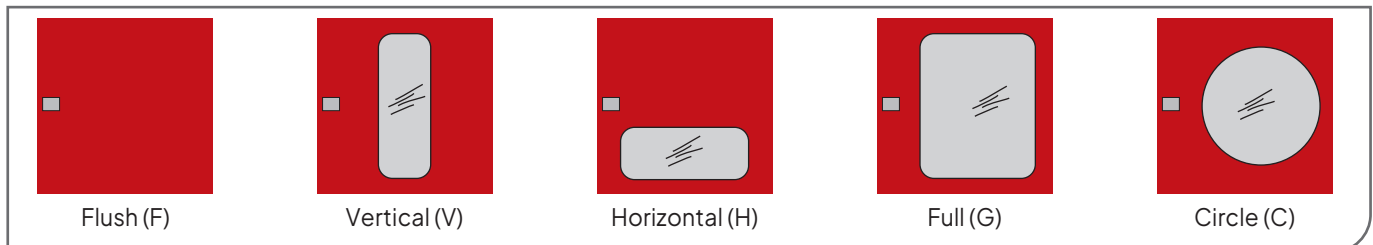

### Glass Selection

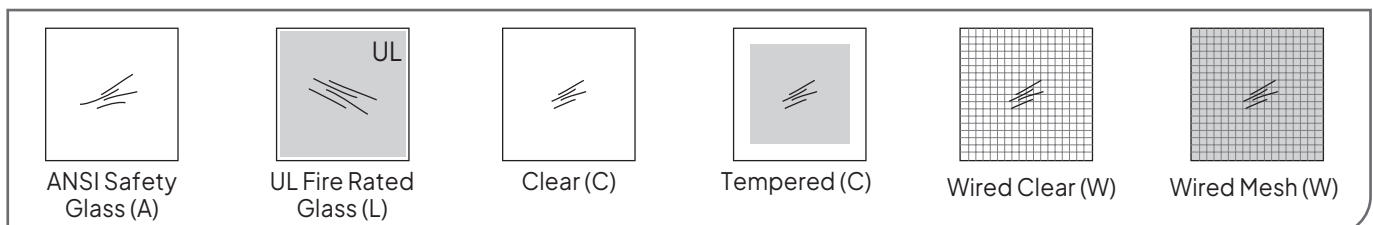



Since 1983, SFFECO has been a trusted name in fire protection, known for innovation and quality worldwide.

With state-of-the-art facilities in Riyadh and Dubai, we deliver a complete range of firefighting solutions that meet international standards.

Our innovative approach and comprehensive product portfolio make SFFECO the one-stop destination for reliable fire protection products and services.

## شركة المصنع السعودي لأجهزة الإطفاء SAUDI FACTORY FOR FIRE EQUIPMENT Co.

### FACTORY & HEAD OFFICE - RIYADH

2nd Industrial Area, Al-Kharj Road, Riyadh, KSA, P.O. Box: 58469, Riyadh 11515  
Tel : +966 11 2650070, E-mail: riyadh@sffeco.com.sa

### JEDDAH BRANCH

P.O. Box: 16769, Jeddah - 21474, KSA  
Tel : +966 12 670 6009,  
E-mail: jeddah@sffeco.com.sa

### DAMMAM BRANCH

P.O. Box: 7162, Dammam - 31462, KSA  
Tel : +966 13 8351961,  
E-mail: dammam@sffeco.com.sa

### MADINAH BRANCH

Tel : 0148660959, 0148283256,  
E-mail: madinah@sffeco.com.sa

