

Single Row Cylinder battery frame unit with Manifold

P/N: SFR-CDES-ME-01-xx(a)

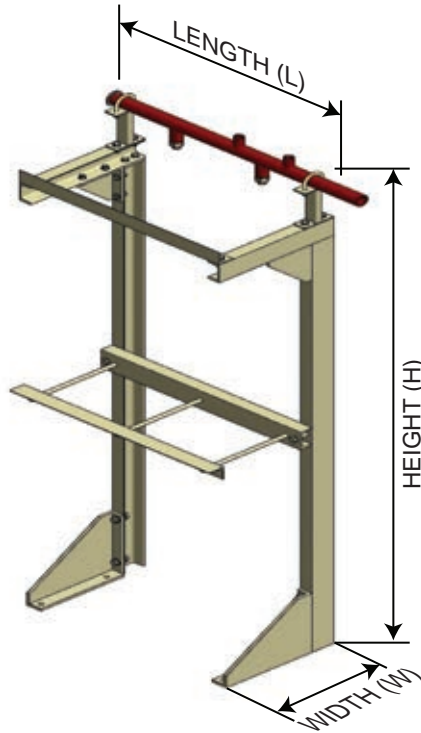

Single Row Cylinder battery frame unit with Manifold	P/N: SFR-CDES-ME-01-xx(a)
Standard	UL 2127, NFPA 12
Material	Battery Frame : Mild Steel Manifold : Seamless (SCH.80)
Temperature Ratings	-18°C to +54.4° C
Test Pressure	173 Bar

(a) Where xx indicates the number of cylinders

NOTE: L, H, & W shall be as per cylinder number, diameter and height.

Double Row Cylinder battery frame unit with Manifold

P/N: SFR-CDES-ME-02-xx(a)

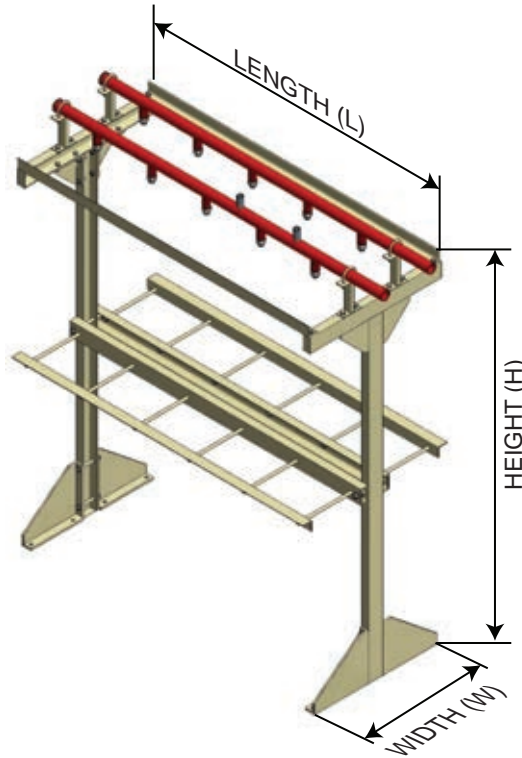

Double Row Cylinder battery frame unit suitable for 10 cylinder unit with Manifold	P/N: SFR-CDES-ME-02-xx(a)
Standard	UL 2127, NFPA 12
Material	Battery Frame : Mild Steel Manifold : Seamless (SCH.80)
Size	L-1870 x W-860 x H-2050
Temperature Ratings	-18°C to +54.4° C
Test Pressure	173 Bar

(a) Where xx indicates the number of cylinders

NOTE: L, H, & W shall be as per cylinder number, diameter and height.